



# Manhole Products

48" Type 204b Maintenance Hole  
City of Seattle Standard Plan

### Grade Adjustment Rings Available

- 2", 3", 4", 6"

### Hole or Knock Out Dimensions

- Maximum hole size is 36 inches
- 8 inches of minimum distance between holes
- 2 inch diameter lifting holes provided
- Cored, cast-in and custom block-out/knock-outs available

### Conformity Standards

- AST C478 Manhole
- ASTM C443 rubber gasket joint
- ASTM D4101 & 232A/B polypropylene steps and ladders
- Washington State APWA / WSDOT Standard

### Options Available

- Pre-channeled base
- Specialized coatings
- Custom hatches
- 1' thru 10' Polypropylene ladders
- Kor-N-Seal boots

### Section Specifications

Height	Section	Base	Base Slab	Flat Top
6"	410 LBS	-	1,698 LBS	
12"	859 LBS	2,193 LBS		
24"	1,735 LBS	3,069 LBS		
36"	2,612 LBS	3,946 LBS		1,667 LBS
48"	3,489 LBS	4,823 LBS		
60"	4,365 LBS	5,699 LBS		
72"	5,069 LBS	6,403 LBS		

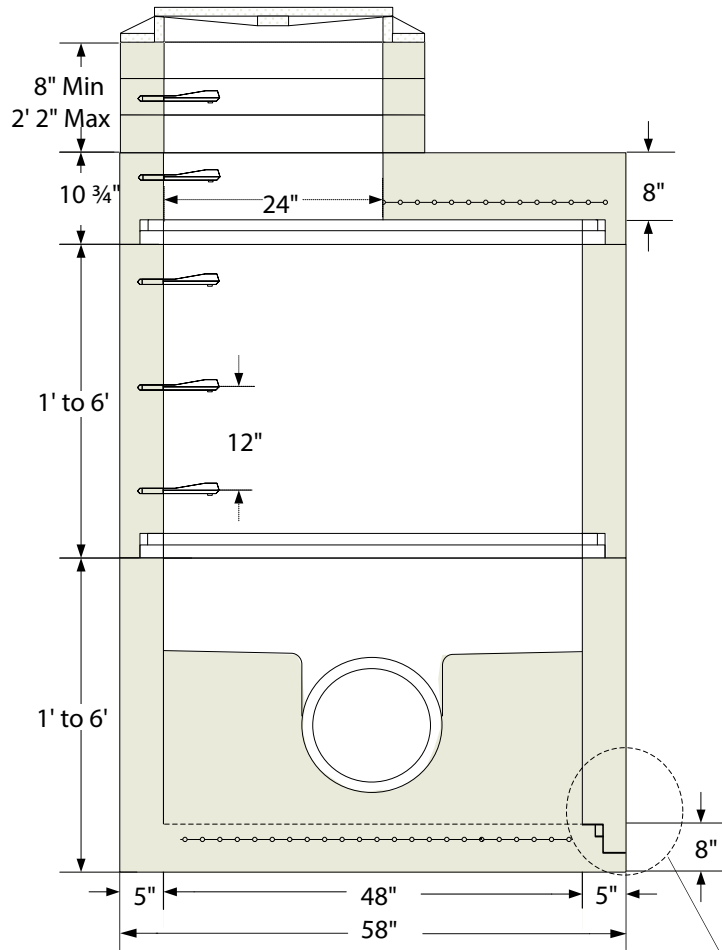

### Top Slab Plan View Options

### Gasket Shown Uncompressed

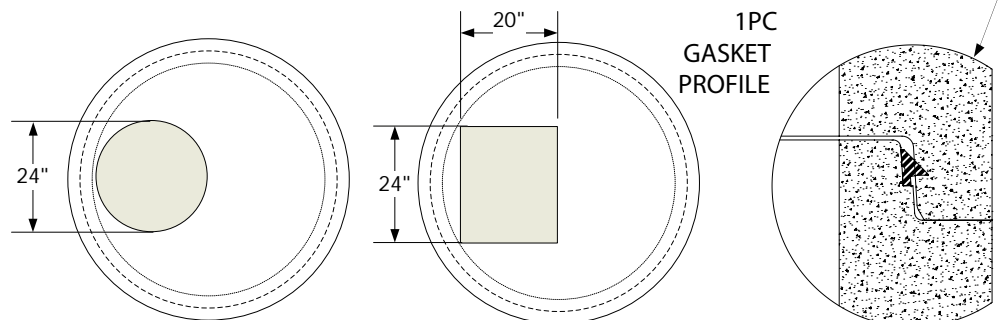

Note: Drawings not to scale

[www.shopeconcrete.com](http://www.shopeconcrete.com)

1-800-422-7560 [TOLL FREE]



Shope Concrete, LLC  
1618 East Main Avenue  
Puyallup, WA 98372-3142

(253) 848-1551  
Fax Line 1 (253) 845-0292  
Fax Line 2 (253) 864-6172

